

Driver: Lance Norick

Track: The Farm 1

Air Temp: 90'sF

Surface Description: Clay

Avg. Lap Time: 33.5 sec.

## Front Suspension

Shock Spring: Blue

Shock Piston: 53/54

Shock Oil wt: 60 wt.

Shock Length (Center to Center): 105mm

Toe-IN:

Toe-Out: 1 degree

Front Ride Height: Just above level

Sway Bar: 2.7mm

Camber: Neg: 1 degrees

Pos:

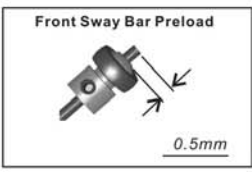
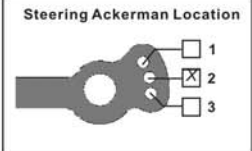
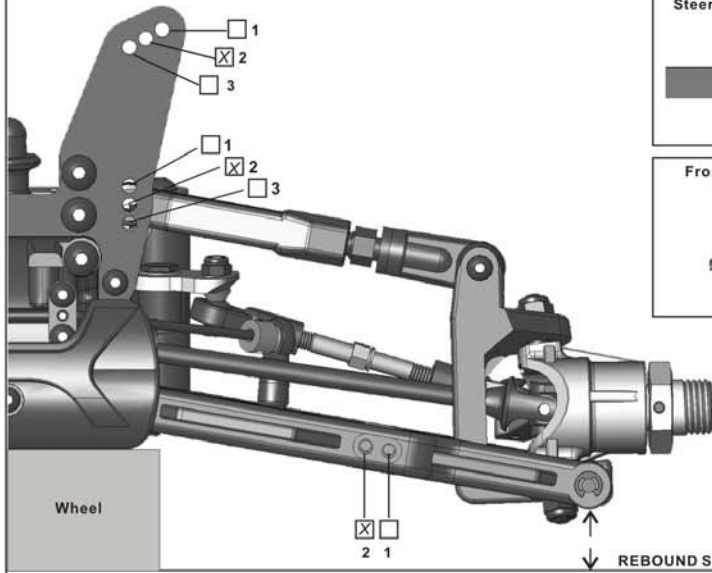
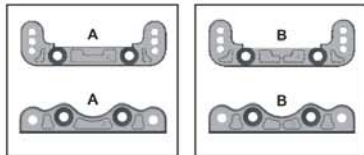
 Camber Block:  A/A  B/B

Notes:

## Rear Suspension

Shock Spring: Blue

Shock Piston: 53/53

Shock Oil wt: 50 wt.

Shock Length (Center to Center): 125mm

Rear Ride Height: Arms level

Sway Bar: 2.6mm

Camber: Neg: 1 degree

Pos:

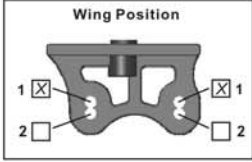
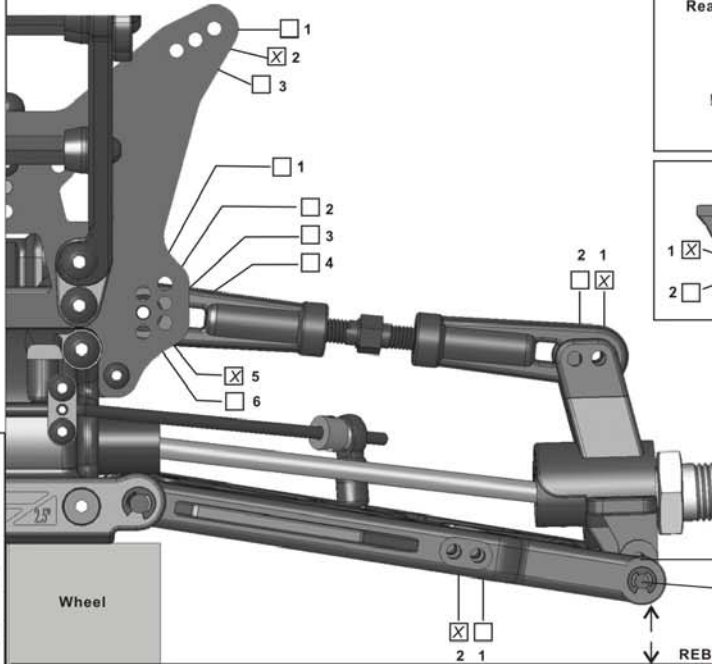
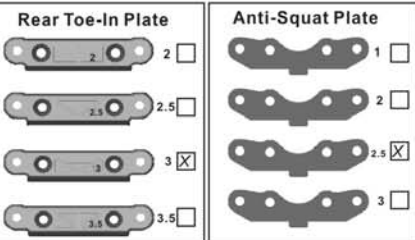
 Rear Hub/Wheelbase:  Forward  Middle  Back

Notes:

## Differentials

Front Type: Standard Oil: 7,000

Center Type: Standard Oil: 10,000

Rear Type: Standard Oil: 2,000

## Tires

Front Type: P.L. CrimeFighter Compound: M2 Foam: Stock

Rear Type: P.L. CrimeFighter Compound: M2 Foam: Stock

Note:

## Engine

Type: Picco P7R

Head Clearance: Std. Pipe: Jammin JP-2

Fuel: O'Donnell % 30 Plug: O'Donnell 99

Needle (Top): (Bottom):

Note:

## Clutch

Shoe Brand: Ofna Compound: Blue Aluminum

Spring Brand: Ofna Gold Tension: 1.1mm

 Gearing:  13T  14T To  46T  48T

Note: