



SETUP SHEET

TRACK: SIZE:

TRACTION:

SURFACE:

DRIVER: \_\_\_\_\_

DATE: \_\_\_\_\_

- OPEN
- MEDIUM
- TIGHT

- HIGH
- MEDIUM
- LOW

- SMOOTH
- MEDIUM
- BUMPY

FRONT SUSPENSION

IN: \_\_\_\_\_  
TOE ANGLE  OUT: \_\_\_\_\_

RIDE HEIGHT  
FRONT: \_\_\_\_\_

CAMBER  POS: \_\_\_\_\_  
 NEG: \_\_\_\_\_

REBOUND STOP: \_\_\_\_\_

SWAY BAR  2.5mm  
 OTHER \_\_\_\_\_

FRONT SHOCKS

OIL: \_\_\_\_\_  
PISTONS: \_\_\_\_\_  STANDARD  DRILLED  
SPRING: \_\_\_\_\_

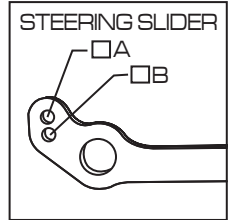
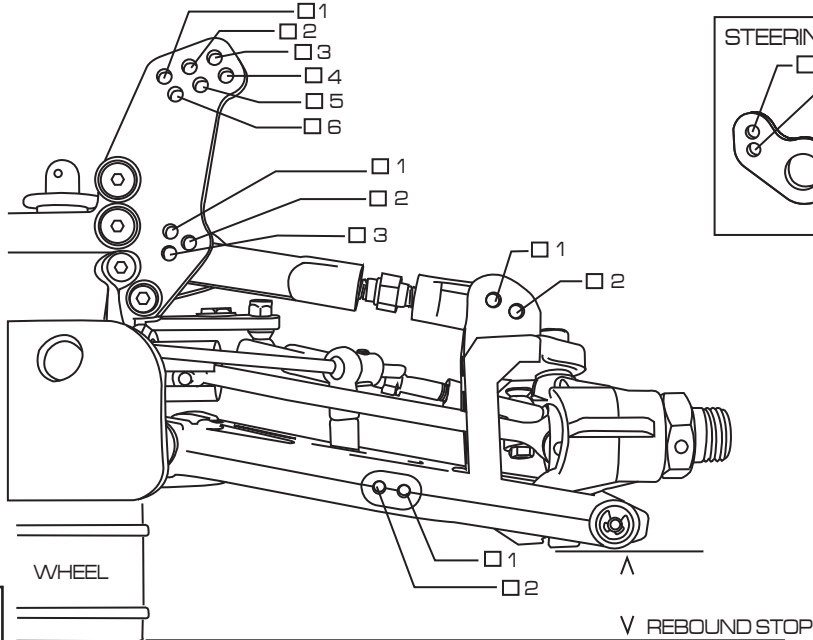

NOTES: \_\_\_\_\_  
\_\_\_\_\_  
\_\_\_\_\_

REAR SUSPENSION

TOE-IN PLATE:  1°  2°  3°

RIDE HEIGHT  
REAR: \_\_\_\_\_

HUB POSITION  UPPER: \_\_\_\_\_  
 LOWER: \_\_\_\_\_

CAMBER  POS: \_\_\_\_\_  
 NEG: \_\_\_\_\_

REBOUND STOP: \_\_\_\_\_

SWAY BAR  2.5mm  
 OTHER \_\_\_\_\_

REAR SHOCKS

OIL: \_\_\_\_\_  
PISTONS: \_\_\_\_\_  STANDARD  DRILLED  
SPRING: \_\_\_\_\_

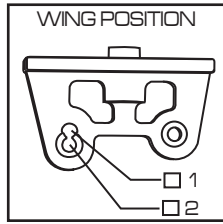
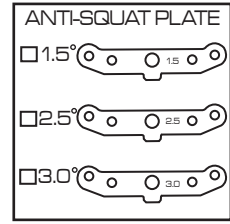
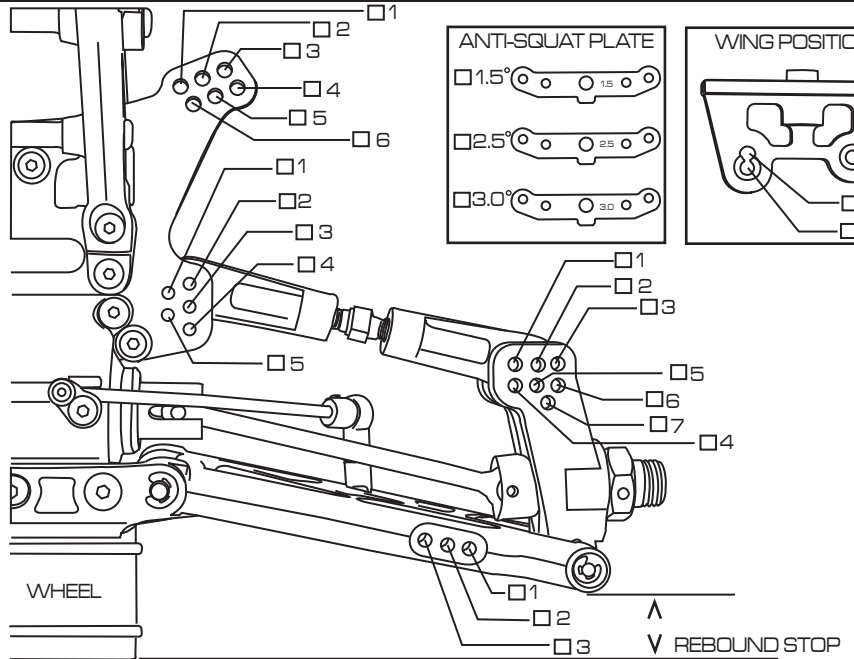

NOTES: \_\_\_\_\_  
\_\_\_\_\_  
\_\_\_\_\_

DIFF OIL FRONT: \_\_\_\_\_  
CENTER: \_\_\_\_\_  
REAR: \_\_\_\_\_

TIRES FRONT REAR  
TYPE: \_\_\_\_\_ TYPE: \_\_\_\_\_  
INSERT: \_\_\_\_\_ INSERT: \_\_\_\_\_

ENGINE TYPE: \_\_\_\_\_ MUFFLER: \_\_\_\_\_  
GASKET: \_\_\_\_\_ mm FUEL: \_\_\_\_\_  
PLUG: \_\_\_\_\_

CLUTCH  13T CLUTCH SHOES  
CLUTCH BELL  14T  3 SHOE  
 OTHER \_\_\_\_\_ T  4 SHOE