



FORCE 25 PULL START ENGINES

Thank you for purchasing a OFNA engine. We appreciate your choice and know you will enjoy running it. Please note that the Force information in engine box is subject to change with not notice.

Carburetor Low end and barrel stop screws are pre-set by factory.... Do not change until break-in is done.

NEW ENGINE BREAK-IN

Your OFNA engine is extremely tight when the piston is at the top of the stroke and turning the crankshaft by hand. This is normal for a new ABC type engine. The piston and sleeve are matched for fit and the top of the sleeve is tapered for a tight fit. As you run your engine, this tightness should diminish. There is no cause for alarm, because as the engine warms up, the brass sleeve will expand faster than the aluminum piston and the engine will turn freer.

As with any new engine, there are many high spots and tight fits in the matching process. High spots create hot spots that must be broke-in. Therefore, the break-in process is very important to provide good service by the OFNA engine. So, you must run the engine rich (COOL) for the first three tanks of fuel. We recommend using one gallon of 20% BLUE THUNDER OR BYRON'S 2000 as break-in fuel. Other break-in type fuels or added oil is NOT needed. DO NOT OVER REV THE ENGINE WHEN FIRST STARTING, this could break the piston and over heat sleeve. Let engine run at low RPM for one tank to break-in connecting rod bearing before starting full break-in.

Break-in the engine in the car, by running the engine at a rich setting. Run the car from a slow to fast speed with short bursts of speed. You need to buildup a little heat in the engine, but not too hot. In a rich setting, the engine will run cold. In the leaner setting the engine run hot, this is not good yet. Do not heat up the engine too much at this time. After about one (1) tank, turn the Master Needle Valve, clock wise, 1/8 of a turn leaner or clockwise. Keeping the fuel tank full, continue the process until you slowly turn the Master Needle Valve, 1/8 of turn each time, too a leaner point and in which the engine runs at high RPM and power, but still keep max temp. of 250 deg. F. At this point you must stop, too lean of a setting will heat up engine and damage the piston. A normal operating temperature is around 220 to 270 Deg. Temperatures of 300 Deg. and above will damage engine and shorten life.

NEEDLE SETTINGS

Master Needle Valve - main control for fuel mixture. Set at 3 to 3 1/2 turns from closed. Adjust this needle for maximum RPM and power without being too lean or too hot. Make sure you start at bottom of needle seat!!

Side Carburetor Needle (Low Speed) - This needle is in the center side of the carburetor and provide throttle response. It is not the idle adjustment. Set FLUSH with the brass sleeve. Turning in is Lean and Out is Rich. Do not adjust this needle until the Master Needle is set for power and top speed. This will only effect throttle response.

FOR THREE NEEDLE CARBURETORS, DO NOT ADJUST MID RANGE NEEDLE, PRESET BY FACTORY

Barrel Stop Screws - Used for adjusting Idle. Set for 1/16th inch gap to start new engines. You can open more for faster idle.

**USE LONG GLOW PLUG WITHOUT IDLE BAR,
OFNA/PICCO #51007 IS RECOMMENDED**



FORCE 25 PULL START ENGINES

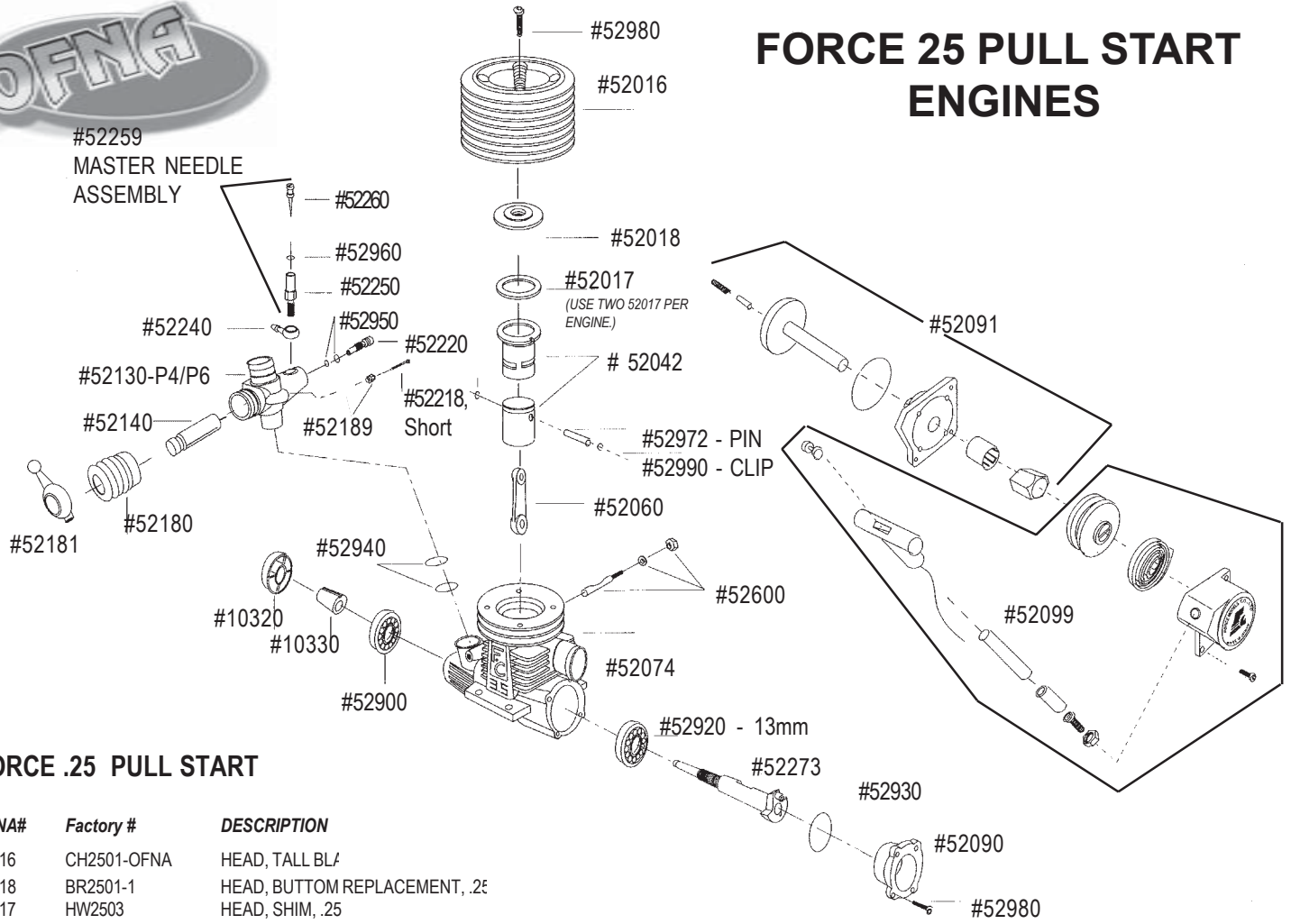

FORCE .25 PULL START

OFNA#	Factory #	DESCRIPTION	
52016	CH2501-OFNA	HEAD, TALL BL/	
52018	BR2501-1	HEAD, BUTTOM REPLACEMENT, .25	
52017	HW2503	HEAD, SHIM, .25	
52042	CP2504/5A	CYLINDER SLEEVE AND PISTON, .25	
52060	CR2106	CONNECTING ROD (ALUM. 7075S)	14.95
52074	CK2507	CRANKCASE, FORCE .25	44.95
52273	CS2108T	CRANKSHAFT, SG, PULL START, .25	75.95
52090	FM-2109	REAR BACK COVER	6.25
52091	RS-12/17	REAR BACK PLATE UNIT, PULL START	24.95
52098	RS-18/19	SPRING AND PIN, PULL START	3.95
52099	RS-1/11	PULL START UNIT W/ ROPE	24.95
52100	2110	CARBURETOR SET PIN	3.25
52110	2111	SLIT METAL CONE	2.95
52120	2112	DRIVE HUB	3.25
52130	2113	CARBURETOR BODY, P4 / P6	11.75
52131	21131(7mm)	CARBURETOR COMPLETE, 7mm	61.95
52140	2114	THROTTLE BARREL	6.75
52150	2115	THROTTLE NEEDLE	3.75
52160	2116	SPRING, THROTTLE NEEDLE	1.25
52170	2117	BOOT, THROTTLE	2.50
52180	2118	CAP, THROTTLE NEEDLE(OLD)	2.25
52181	2118ST	BALL END, THROTTLE NEEDLE	5.95
52190	2119/20	BARREL STOP BASE AND NUT	2.25
52219	2121	BARREL STOP SCREW	2.25
52220	2122	LOWEND NEEDLE	4.75
52230	2123	WASHER, ALUMINUM, 1 PC	0.95
52240	2124	FUEL SUPPLY NIPPLE	2.50
52250	2125	MAIN NEEDLE SEAT	4.25
52260	2126	MAIN NEEDLE	3.75
52900	B-1	BEARING, OUTSIDE, 607Z	5.95
52920	B-3	BEARING INSIDE, 13mm	18.95
52930	L-1	SEAL, REAR COVER	1.75
52940	L-2	SEAL, CARBURETOR	1.25
52950	L-3	SEAL, LOW END NEEDLE	0.95
52960	L-4	SEAL, MAIN NEEDLE	0.95
52972	P007	PIN, PISTON, .25	2.95
52980	FMS-1/2	SCREW SET, 8 PCS	2.50
52990	FMW-1	CLIPS, "G", 2 PCS.	1.95