

ASSEMBLY OF NEW "K" STYLE DIFFERENTIAL CASE AND GEARS

31324 - FRONT OR REAR DIFF UNIT 31325 - CENTER DIFF UNIT

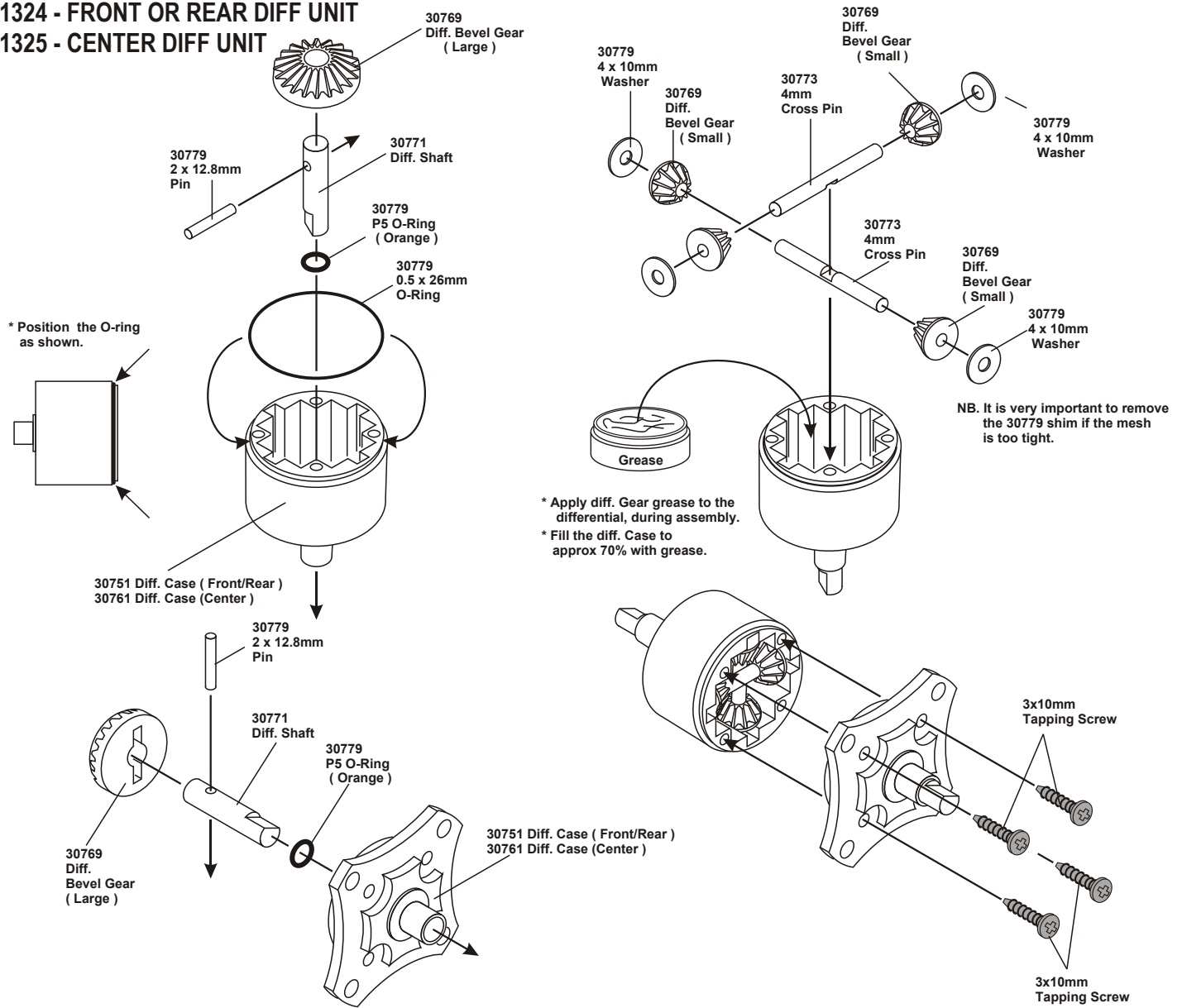

ASSEMBLY OF THE BEVEL GEAR

(Builds two differentials for front and rear.)

