

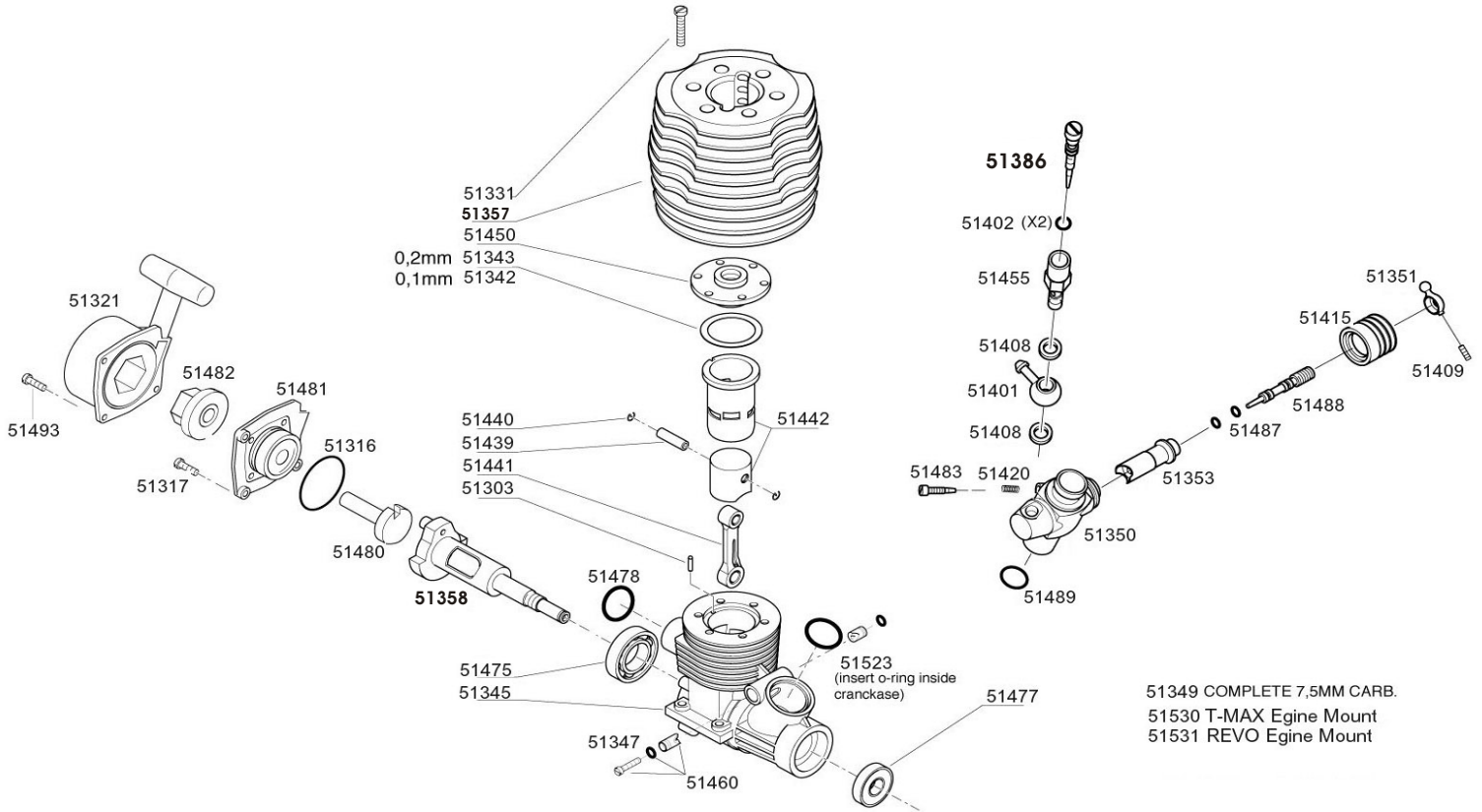

**Picco .26Max JL Red Dot  
Part #51225 w/ps**

**TECHNICAL DATA**

- Cubic Capacity.....4.27cc
- Stroke.....16mm
- Bore.....18.2mm
- Rpm.....34000
- Hp.....2.7
- Weight.....320gr



51349 COMPLETE 7,5MM CARB.  
51530 T-MAX Engine Mount  
51531 REVO Engine Mount

**.26MAX JL RED DOT PARTS LIST**

51321	PULLSTART ASSEMBLY, PICCO .26MAX JL	18.95	51420	SPRING, AIR SCREW SPRING	0.95
51415	BARREL BOOT, SILICONE	5.45	51439	WRIST PIN, .26-.28 PICCO	8.95
51303	PIN REF., CYLINDER	1.95	51440	RETAINER, WRIST PIN CLIPS .26P	1.95
51316	O-RING, REAR COVER P7, P9	1.95	51441	CONNECTING ROD,MAX21,26 & 26P2	51.95
51317	SCREWS, REAR COVER, 4 PCS.	4.95	51442	PISTON/SLEEVE, .26 PICCO	74.95
51331	SCREW SET, HEAD, COMP.21	2.95	51450	BUTTON, HEAD INSERT,.26&26MAX	30.95
51342	CRANK, JLR EVO 3	159.95	51455	HOUSING, MASTER NEEDLE (NEW)	6.50
51343	PISTON/SLEEVE .27 PICCO	93.95	51460	CARB. LOCKING PIN,NEW TYPE .12	5.95
51345	CRANKCASE .26MAX	79.95	51475	BEARING .13 INSIDE .21 MAX	33.95
51347	O-RING CARB. LOCK PIN	1.95	51477	BEARING FRONT .21 MAX	22.95
51349	CARB. COMPLETE .26MAX	99.95	51478	EXHAUST O-RING P2 4PCS	4.95
51350	CARB. BODY .26MAX	69.95	51480	PULLSTART AXLE .26 MAX	14.95
51351	BALL JOINT CARB. .26MAX	11.95	51481	REAR COVER PULL START, MAX 21	29.95
51386	MASTER NEEDLE .28 .26 NEW 2009	5.95	51482	ONE-WAY COMPLETE .21,.26 MAX	29.95
51353	CARB. DRUM .26MAX	19.95	51483	SCREW, BARREL STOP, MAX 21	0.99
51357	HEAD, .26MAX JL	99.95	51487	O-RINGS, LOW END, MAX 21 2PC	3.95
51358	CRANKSHAFT .26MAX JL RED DOT	115.95	51488	NEEDLE, LOW END, MAX 21 & 26	9.95
51401	FUEL FITTING	4.95	51489	O-RING VENTURI	1.95
51402	O-RING, M.NEEDLE, 2 PCS.	1.95	51493	SCREW .21 MAX 3X6MM 4PCS	2.95
51408	WASHERS, ALUM. 2 PCS.	1.95	51523	O-RING, CARB. 2PCS.	0.99
51408	WASHERS, ALUM. 2 PCS.	1.95	51530	MOUNT FOR T-MAXX, 26MAX ENG	20.95
51409	SET SCREW 3x3mm	0.95	51531	MOUNT FOR REVO, 26MAX ENG	20.95



**PICCO .26MAX JL RED DOT**  
**PART # 51225 W/PULLSTART**

Thank you for purchasing a OFNA engine. We appreciate your choice and know you will enjoy running it. Please note that the OFNA information in engine box is subject to change without notice.

Carburetor Low end and barrel stop screws are pre-set by factory. Do not change until break-in is done.

### NEW ENGINE BREAK-IN

Your OFNA engine is extremely tight when the piston is at the top of the stroke and turning the crankshaft by hand. This is normal for a new ABC type engine. The piston and sleeve are matched for fit and the top of the sleeve is tapered for a tight fit. As you run your engine, this tightness should diminish. There is no cause for alarm, because as the engine warms up, the brass sleeve will expand faster than the aluminum piston and the engine will turn free.

As with any new engine, there are many high spots and tight fits in the matching process. High spots create hot spots that must be broke-in. Therefore, the break-in process is very important to provide good service by the OFNA engine. So, you must run the engine rich (COOL) for the first two tanks of fuel. We recommend using BYRON'S 3000 as break-in fuel. Other break-in type fuels or added oil is NOT needed.

DO NOT OVER REV THE ENGINE WHEN FIRST STARTING, this could break the piston and over heat sleeve. Let engine run at low RPM for one tank to break-in connecting rod bearing before starting full break-in.

Break-in the engine in the car, by running the engine at a rich setting. By adjusting the top end one turn out from Factory setting which equal from close to 3 turn out in total. Run the car from a slow to fast speed with short bursts of speed. You need to buildup a little heat in the engine, but not too hot. In a rich setting, the engine will run cold. In the leaner setting the engine run hot, this is not good yet. Do not heat up the engine too much at this time. After about two (2) tank, turn the Master Needle Valve, clock wise, 1/8 of a turn leaner or clockwise. Keeping the fuel tank full, continue the process until you slowly turn the Master Needle Valve, 1/8 of turn each time, too a leaner point and in which the engine runs at high RPM and power, but still keep **MAX** Temp. of **250 deg**. F. At this point you must stop, too lean of a setting will heat up engine and damage the piston. **A normal operating temperature is around 220 to 250 Deg**. Temperatures of 260 Deg. and above will damage engine and shorten life.

### NEEDLE SETTINGS

Master Needle Valve - main control for fuel mixture. Set at 3 turns from closed. Adjust this needle for maximum RPM and power without being too lean or too hot. Make sure you start at bottom of needle seat!!

Side Carburetor Needle (Low Speed) - This needle is in the center side of the carburetor and provide throttle response. It is not the idle adjustment. Set NEEDLE two turn out from ball end. Turning in is Lean and Out is Rich. Do not adjust this needle until the Master Needle is set for power and top speed. This will only effect throttle response.

Barrel Stop Screws - Used for adjusting Idle. Set for 1/16th inch gap to start new engines. You can open more for faster idle.

**OFNA/PICCO GLOW PLUG IS RECOMMENDED**  
**51008 - STANDARD GLOW PLUG HOT**  
**51007 - STANDARD GLOW PLUG MED**